

Continuous Spinal Anesthesia and Analgesia in Obstetrics

Craig M. Palmer, MD

The development of the technique of continuous spinal anesthesia as it relates to the obstetric population is recounted. The advantages and disadvantages of continuous spinal anesthesia are examined, currently available catheters and kits are reviewed, and strategies for the management of continuous spinal techniques for labor analgesia and surgical anesthesia are discussed. Continuous spinal anesthesia may have particular value over other regional techniques in several specific clinical circumstances. (*Anesth Analg* 2010;111:1476–9)

Continuous spinal anesthesia is one of the most useful, versatile, and reliable techniques available for providing analgesia and anesthesia, in both obstetric and nonobstetric populations. Despite its inherent advantages, it is also one of the most underutilized of regional anesthetic techniques. Though the use of continuous spinal anesthesia in the obstetric population dates back almost 7 decades, wider use and acceptance have been hampered primarily by limitations of the available equipment.

In 1906, Henry P. Dean described the use of an intermittent-injection, continuous spinal technique for surgical anesthesia, accomplished by leaving the spinal needle “in the canal during the operation” (Table 1).¹ More than 3 decades later, speaking before the Philadelphia Academy of Surgeons, William T. Lemmon, a surgeon from Jefferson Medical College in Philadelphia, PA, described the use of malleable 17- to 18-g “German silver” needles 2.5 to 3.5 inches in length attached to a stopcock and rubber tubing to deliver local anesthetic as necessary; a special mattress with a gap to accommodate the in-dwelling needle was required (Fig. 1).² In 1944, Hinebaugh and Lang, obstetricians from Jefferson, first reported the use of the technique for labor analgesia.³ Describing their experience with over 50 cases, they found that 15 mg of 5% procaine, injected at the first or second lumbar interspace, provided complete or partial relief of labor pain within 3 minutes in 96% of their patients, lasting 30 to 40 minutes. Not surprisingly, they noted difficulty keeping needles in place in the spinal canal during labor, and because of the lack of a delivery room table with the special split mattress, they usually removed the needle before delivery. Noting the advantages of the technique, they reported little effect on arterial blood pressure in most patients, and stated, “We were impressed by the apparent acceleration of cervical dilation.” Unfortunately, 42% of the patients suffered “rather severe but transient” headache after delivery. In the same year, Lemmon and Hager reported the use of their technique for 140 cesarean deliveries.⁴

The necessity of securing needles in the subarachnoid space clearly limited the usefulness of the continuous spinal anesthesia technique. The first reported attempt to

overcome this limitation was in 1944, when Edward Tuohy described the use of a 4-French ureteral catheter passed through a 15-g spinal needle into the subarachnoid space.⁵ While this technique made continuous access easier (and decreased the fear of needle breakage in the patient), the large hole in the dura created by the 15-g needle, and the inevitable postdural puncture headache (PDPH), appears to have been enough to prevent its widespread use. It was another 20 years before the next advance in continuous spinal anesthesia: Bizzarri et al. reported continuous spinal anesthesia using a 0.010-inch diameter (24 g) catheter, which they passed through a 20- to 21-g spinal needle.⁶ Their original report of 27 cases included 5 cesarean deliveries accomplished using the technique. On the basis of the paucity of reports in the literature, it seems this apparent improvement in equipment did not become widely adopted in the obstetric population.

Over 20 more years passed before advances in technology expanded the potential of the continuous spinal anesthesia technique. In 1987, Hurley and Lambert presented an abstract (later published in manuscript form⁷) at the annual meeting of the American Society of Regional Anesthesia, describing the use of a 32-g “microcatheter” passed through a 26-g spinal needle. The surge in enthusiasm for continuous spinal anesthesia after this report and others, especially within the obstetric anesthesia community, coincided with the introduction to the market of a number of catheters between 28 g and 32 g that could be passed through needles 22 g and smaller. These microcatheters, and the smaller spinal needles required for their placement, promised to decrease the incidence of PDPH to levels allowing more widespread use of continuous spinal anesthesia. A number of investigators were just beginning to explore the use of microcatheters in the obstetric population when Rigler et al.⁸ described 4 cases of permanent neurologic damage (cauda equina syndrome) associated with microcatheter continuous spinal anesthesia. Subsequent investigations proved that the complication was the result of maldistribution of local anesthetic in lumbosacral cerebrospinal fluid (CSF). While the microcatheters themselves were not found to be inherently dangerous, their very small internal diameter severely limited the flow rate of local anesthetic injected through them. This apparently resulted in laminar flow of the local anesthetic within the CSF, exposing some nerve roots to very high concentrations of local anesthetic. Faced with these reports, the United States Food and Drug Administration (FDA) made the decision to withdraw approval of all catheters 24 g and smaller. The FDA’s reasoning was that, because there were no medications

From the Department of Anesthesiology, University of Arizona College of Medicine, Tucson, Arizona.

Accepted for publication August 9, 2010.

Address correspondence to Craig M. Palmer, MD, Professor of Clinical Anesthesiology, University of Arizona Health Sciences Center, 1501 N. Campbell Ave., Tucson, AZ 85724. Address e-mail to cpalmer@u.arizona.edu.

Copyright © 2010 International Anesthesia Research Society
DOI: 10.1213/ANE.0b013e3181f7e3f4

Table 1. Notable Milestones in Use of Continuous Spinal Anesthesia

Year	Investigators	Description
1906	Henry P. Dean	Intermittent-injection continuous spinal anesthesia for surgical anesthesia via a needle left in situ in the spinal canal.
1944	William T. Lemmon, Henry G. Hager	Described use of malleable needles with attached rubber tubing for continuous spinal anesthesia for surgical anesthesia; required a special mattress with a cut-out to accommodate the needle in the patient's back; first reported use in obstetric population for cesarean delivery.
1944	Mahlon C. Hinebaugh, Warren R. Lang	First reported use of continuous spinal anesthesia for labor analgesia; used method of Lemmon and Hager.
1944	Edward Touhy	Used 4-French ureteral catheter in subarachnoid space for continuous spinal anesthesia for surgical anesthesia; passed catheter via a 15-g needle.
1964	Dante Bizzarri, Joseph G. Guiffrida	Reported use of a 0.010-inch diameter (24 g) catheter that could be passed through a 20- to 21-g spinal needle; used for surgical anesthesia.
1987	Ronald J. Hurley, Donald H. Lambert	Use of a 32-g microcatheter for surgical anesthesia.
1991	Mark L. Rigler, Kenneth Drasner et al.	Reported cauda equina syndrome in 4 patients after continuous spinal anesthesia with 28-g and 20-g catheters for surgical anesthesia.
2008	Valerie A. Arkoosh, Craig M. Palmer et al.	Continuous spinal anesthesia for labor analgesia with sufentanil and bupivacaine in over 300 parturients with a 28-g catheter.

Figure 1. A depiction of the special mattress (1) described by Lemmon in 1940. (2) A malleable silver needle was placed in the patient's back, which required a cut-out (2) in the mattress so that the patient could be placed supine for operation while maintaining the needle in place. Flexible rubber tubing (3) was run from the needle to the head of the mattress and gurney so additional local anesthetic could be injected as necessary. This is the same mattress used by Hinebaugh and Lang to administer continuous spinal anesthesia for labor, reported in 1944.¹ (Adapted from the original depiction in Lemmon WT. A method for continuous spinal anesthesia; a preliminary report. *Ann Surg* 1940;111:141-4.)

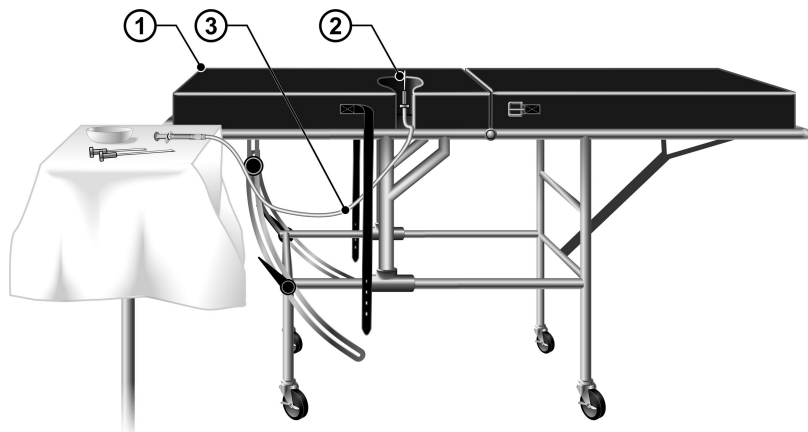

approved for administration via these catheters, there was no reason to make the catheters available.

In 1996, the FDA granted an Investigational Device Exemption to compare the safety of continuous spinal administration of sufentanil and bupivacaine using a 28-g catheter with continuous epidural administration of the same medications for labor analgesia and anesthesia. This eventually led to the publication of the largest randomized clinical trial of continuous spinal anesthesia in the obstetric population, over 400 patients, three-quarters of whom received continuous spinal anesthesia for labor with the 28-g catheter, placed through a 22-g Sprotte-type spinal needle.⁹ Though the study was designed primarily to assess the safety of continuous spinal anesthesia with the 2 medications, it also provided some information on obstetric and maternal outcomes. No permanent neurologic changes occurred in the continuous spinal anesthesia group; given the sample size, this finding suggests that the risk of neurologic damage with this catheter is <1%. Labor analgesia for the intrathecal catheter patients was managed primarily with sufentanil, with bupivacaine added for breakthrough pain. In comparison with epidural catheter patients, the continuous spinal anesthesia group had significantly lower pain scores during labor in the first 60 minutes after initiation of analgesia, less motor block, and

not surprisingly, higher pruritus scores. Maternal satisfaction assessed after delivery was higher with the continuous spinal anesthesia technique. No differences were found in any obstetric or neonatal outcomes. Even with the "atraumatic" 22-g Sprotte needle, a trend toward more PDPHs was evident in the continuous spinal anesthesia group (9% in the continuous spinal anesthesia group in comparison with 4% in the epidural group, though only half the continuous spinal anesthesia patients with headache required epidural blood patch therapy). Unfortunately, before completion of the study, rights to manufacture and market the catheter changed hands; at present there are no plans to market the catheter.

A completely different system, using a catheter-over-needle design, is currently available in some European markets. Two recent series have investigated the use of this catheter for cesarean delivery anesthesia. Alonso et al. used this system for 92 elective cesarean deliveries, 90% of which had a 24-g catheter placed.¹⁰ For reasons that are not clear, the group reported a 14% failure rate in providing surgical anesthesia in patients in whom the catheter was successfully placed, much higher than the 2% failure rate reported by Arkoosh et al. in the labor analgesia study. Furthermore, Alonso et al. also reported a 28% incidence of PDPH (though <1 in 5 of these patients required an epidural

blood patch), suggesting that different criteria for the diagnosis of PDPH may have been used in this study than in the Arkoosh et al. study. Dresner and Pinder used the same 24-g catheter-over-needle system for cesarean delivery anesthesia in 34 patients with a variety of significant cardiac lesions.¹¹ In contrast to Alonso et al., they had no failures, and only 3 of the 34 patients required an epidural blood patch (2 of whom had received multiple dural punctures during the procedure).

Currently in the United States, the only catheters available for continuous spinal anesthesia are epidural catheters and kits. Most commercially available epidural kits include a 17-g or 18-g Tuohy-type needle, which can be used for dural puncture and placement of the catheter in the subarachnoid space. An advantage to using such catheters is the ease with which CSF can be withdrawn, confirming the correct placement of the catheter. The disadvantage is the frequent incidence of PDPH in the obstetric population after dural puncture with needles of this gauge. Also well-suited for continuous spinal anesthesia in the obstetric population are smaller, “pediatric” epidural catheters available from some manufacturers. These catheters are usually 24-g in diameter and can be placed through a 20-g needle, which would presumably result in a decrease in the incidence of PDPH.

There are no randomized clinical trials comparing different medications for continuous spinal anesthesia for either labor analgesia or cesarean delivery anesthesia, but the series mentioned above and a variety of case reports in the literature do provide guidance. Labor analgesia can be provided with either an opioid-only technique, or with an opioid–local anesthetic combination (Table 2). Regardless of the medications used, all should be preservative-free. Although there is no evidence to suggest that hyperbaric local anesthetics (other than lidocaine) are harmful or inferior, the majority of published reports have studied plain, nondextrose-containing local anesthetic solutions, primarily bupivacaine.^a Use of plain solutions should also eliminate concerns about laminar flow within the CSF. Non-dextrose-containing solutions of bupivacaine currently marketed in the United States are actually slightly hypobaric, but this makes little difference in block spread unless the drug is administered while the patient is in an extreme position (for example, full-lateral or steep Trendelenburg). When the drug is administered with the patient in the supine or left uterine displacement positions, spread of the local anesthetic tends to be equidistant in the cephalad and caudad directions from the tip of the catheter.

Care must always be taken to clearly identify the spinal catheter as such, to avoid the possibility that it may be mistaken for an epidural catheter. When possible, different infusion pumps and tubing should be used for management of the spinal catheter, ideally pumps and tubing

^aAlthough it is common for solutions of plain bupivacaine marketed in the United States to be labeled “For infiltration, nerve block, caudal and epidural anesthesia. Not for spinal anesthesia,” this reflects the fact that the U.S. Food and Drug Administration has not approved these specific medication formulations for spinal anesthesia, not that they are unsuitable for spinal anesthesia; they are actually preservative-free and safe. Use of plain bupivacaine in the U.S. is essentially an “off-label” use of the medication. However, any concerns about the formulation of a given medication should always be addressed before neuraxial use.

Table 2. Suggested Solutions for Maintenance of Continuous Spinal Catheter Analgesia and Anesthesia

Technique	Solution ^a
Labor analgesia	
Intermittent bolus ^b	Plain bupivacaine 1.75–2.5 mg + fentanyl 15–20 µg as needed (roughly each 1–2 hours) or Sufentanil 5.0 µg initial bolus, repeated as needed
Continuous infusion ^{c,d}	0.05%–0.125% bupivacaine + fentanyl 2–5 µg/mL @ 0.5–3.0 mL/h and titrated to a T ₆ –T ₁₀ sensory level or Sufentanil 2.5–5.0 µg/h
Surgical anesthesia ^b	Preservative-free 0.5% bupivacaine 5.0 mg (1 mL) + fentanyl 15 µg for the initial dose followed by 0.5-mL boluses of 0.5% bupivacaine (2.5 mg) every 5 minutes until the desired block height is obtained. Repeat the 0.5-mL bupivacaine dose as needed to maintain the desired block height

^a Preservative-free drugs should be used for spinal injections.

^b The epidural catheter and filter has >1 mL of dead space; therefore a continuous spinal catheter should be flushed with 2 mL of saline after each bolus dose.

^c Use of a continuous infusion has the added advantage of maintaining a closed system, decreasing the chance of medication error and risk of contamination.

^d Almost any mixture commonly used for epidural labor analgesia can be used for continuous infusion via a spinal catheter; calculation of the amount of medication per milliliter will allow an appropriate infusion rate to be chosen.

reserved solely for this purpose. When connecting, disconnecting, or injecting the catheter, strict adherence to “clean” technique should be used to decrease the risk of contamination. The timing of removal of the intrathecal catheter is a matter of some controversy. One observational report¹² described a much lower incidence of PDPH after intrathecal catheter placement (20-g catheter placed via an 18-g Tuohy needle) if the catheter was left in place for 24 hours after delivery (6.2%) rather than immediately after delivery (51.4%); other investigators have reported no difference in headache rate.¹³ Until further evidence is available, it is difficult to recommend a single practice regarding the timing of removal. The catheter should be left in place only if maintenance of sterility can be assured.

Regrettably, continuous spinal anesthesia will probably continue to be an infrequently used option in the obstetric population for the foreseeable future because of the unavailability of suitable catheters. PDPH rates that accompany use of currently available catheters and needles are unacceptably high to advocate its routine use. There are a number of situations and comorbidities in which continuous spinal anesthesia becomes an attractive option:

- **Previous spinal surgery.** A small population of patients presenting for delivery have had previous surgery for correction or stabilization of scoliosis or other idiopathic problems, or occasionally trauma. Even if the epidural space can be identified in such patients, spread of injected local anesthetic is often restricted because of scarring or

obliteration of the epidural space. Use of continuous subarachnoid analgesia/anesthesia may overcome this problem.

- **Significant cardiac disease.** As was demonstrated in the series cited above¹¹ and a number of case reports,^{14–16} the continuous spinal technique can be used to provide excellent analgesia or anesthesia with minimal hemodynamic effects. The fragile cardiovascular balance of some parturients with serious cardiac disease requires that the impact of stresses of labor, delivery, and analgesic interventions themselves be limited to the extent possible. Continuous spinal analgesia for labor can be managed with intrathecal opioids alone, which usually have negligible cardiovascular effects. For surgical anesthesia for delivery, local anesthetics can be administered in small incremental doses, allowing the anesthesiologist (and patient) to compensate for undesirable effects.
- **Morbid obesity.** In this group, the rate of failed induction and cesarean delivery is high, and the need for urgent or emergent cesarean delivery during labor is higher than in the nonobese population. Additionally, the rate of epidural failure is higher in morbidly obese parturients¹⁷; a continuous spinal catheter provides a highly reliable route to induce surgical anesthesia if required. The rapid diagnosis of failed neuraxial anesthesia and the low dose of local anesthetic are additional advantages of continuous spinal techniques over epidural anesthesia. This allows for the timely initiation of alternative anesthetic techniques. Finally, the incidence of PDPH may be lower in this population.¹⁸
- **Difficult epidural catheter placement.** This category covers situations in which an unintended dural puncture occurs, or when the palpable landmarks for epidural placement are so poor that it becomes essentially a “blind,” best-guess needle placement. In the former, the dural puncture has already occurred, so it is logical to use the continuous spinal anesthesia technique and possibly avoid a PDPH by retaining the catheter for 24 hours after delivery. In the latter, an intentional dural puncture unequivocally confirms the appropriate placement of the catheter for subsequent use.
- **Difficult airway.** Though somewhat controversial, placing a spinal catheter in a parturient with a difficult airway provides a reliable route to safely induce surgical anesthesia, very rapidly if necessary, without worry about loss of the airway.

In summary, continuous spinal anesthesia can provide excellent labor analgesia and surgical anesthesia if required, and is a very reliable, flexible technique. Fear of PDPH is the primary reason it is infrequently used; however, the relative risk of this treatable side effect should be weighed against the many advantages of the technique in specific, challenging patient populations. Although standard epidural catheters (20 g) may be used for continuous

spinal anesthesia, pediatric epidural catheters (24 g) that can be placed via 20-g needles are available, and are best for premeditated placement. In countries other than the United States, other catheters may be available. ■■

REFERENCES

1. Dean HP. The importance of anesthesia by lumbar injections in operations for acute abdominal disease. *BMJ* 1906;1:1086–90
2. Lemmon WT. A method for continuous spinal anesthesia: a preliminary report. *Ann Surg* 1940;111:141–4
3. Hinebaugh MC, Lang WR. Continuous spinal anesthesia for labor and delivery: a preliminary report. *Ann Surg* 1944;120:143–51
4. Lemmon WT, Hager HG. Continuous spinal anesthesia: observations on 2000 cases. *Ann Surg* 1944;120:129–42
5. Touhy EB. Continuous spinal anesthesia: its usefulness and the technique involved. *Anesthesia* 1944;5:142–8
6. Bizzari D, Guiffreda JG, Bandoc L, Fierro FE. Continuous spinal anesthesia using a special needle and catheter. *Anesth Analg* 1964;43:393–9
7. Hurley RJ, Lambert DH. Continuous spinal anesthesia with a microcatheter technique: preliminary experience. *Anesth Analg* 1990;70:97–102
8. Rigler ML, Drasner K, Krejcie TC, Yelich SJ, Scholnick FT, DeFontes J, Bohner D. Cauda equina syndrome after continuous spinal anesthesia. *Anesth Analg* 1991;72:275–81
9. Arkoosh VA, Palmer CM, Yun E, Sharma SK, Bates JN, Wissler RN, Buxbaum JL, Nogami WN, Gracely EJ. A randomized, double-masked, multicenter comparison of the safety of continuous intrathecal labor analgesia using a 28-gauge catheter vs. continuous epidural labor analgesia. *Anesthesiology* 2008;108:286–98
10. Alonso E, Gilsanz F, Gredilla E, Martinez B, Canser B, Alsina E. Observational study of continuous spinal anesthesia with the catheter-over-needle technique for cesarean delivery. *Int J Obstet Anesth* 2009;18:137–41
11. Dresner M, Pinder A. Anaesthesia for caesarean section in women with complex cardiac disease: 34 cases using the Braun Spinocath® spinal catheter. *Int J Obstet Anesth* 2009;18:131–6
12. Ayad S, Demian Y, Narouze SN, Tetzlaff JE. Subarachnoid catheter placement after wet tap for analgesia in labor: influence on the risk of headache in obstetric patients. *Reg Anesth Pain Med* 2003;28:512–5
13. Van de Velde M, Schepers R, Berends N, Vandermeersch B, De Buck F. Ten years of experience with accidental dural puncture and post-dural puncture headache in a tertiary obstetric anaesthesia department. *Int J Obstet Anesth* 2009;17:329–35
14. Palmer CM, DiNardo JA, Hays RI, Van Maren GL. Use of transesophageal echocardiography for delivery of a parturient with severe pulmonary hypertension. *Int J Obstet Anesth* 2002;11:48–51
15. Velickovic IA, Leicht CH. Continuous spinal anesthesia for cesarean section in a parturient with severe recurrent peripartum cardiomyopathy. *Int J Obstet Anesth* 2004;13:40–3
16. Sakuraba S, Kiyama S, Ochiai R, Yamamoto S, Yamada T, Hashiguchi S, Takeda J. Continuous spinal anesthesia and postoperative analgesia for elective cesarean section in a parturient with Eisenmenger's syndrome. *J Anesth* 2004;18:300–3
17. Hood DD, Dewan DM. Anesthetic and obstetric outcomes in morbidly obese parturients. *Anesthesiology* 1993;79:1210–8
18. Faure E, Moreno R, Thisted R. Incidence of postdural puncture headache in morbidly obese parturients. *Reg Anesth Pain Med* 1994;19:361–3